

Chapter 12- Surface Areas And Volumes

EXERCISE 12.1

Choose the correct answer from the given four options:

1. A cylindrical pencil sharpened at one edge is the combination of
(A) a cone and a cylinder (B) frustum of a cone and a cylinder
(C) a hemisphere and a cylinder (D) two cylinders.

Solution:

(A) a cone and a cylinder



The Nib of a sharpened pencil = conical shape
The rest of the part of a sharpened pencil = cylindrical
Therefore, a pencil is a combination of cylinder and a cone.

2. A *surahi* is the combination of

(A) a sphere and a cylinder (B) a hemisphere and a cylinder
(C) two hemispheres (D) a cylinder and a cone.

Solution:

(A) a sphere and a cylinder

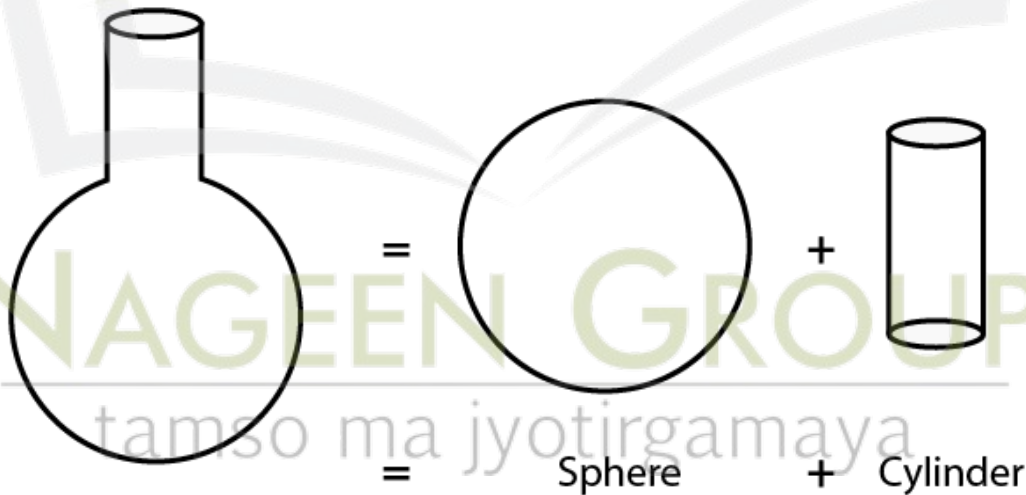

The top part of surahi = cylindrical shape
Bottom part of surahi = spherical shape
Therefore, surahi is a combination of Sphere and a cylinder.

3. A plumbline (*sahul*) is the combination of (see Fig. 12.2)

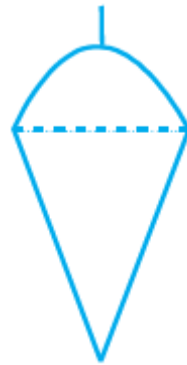
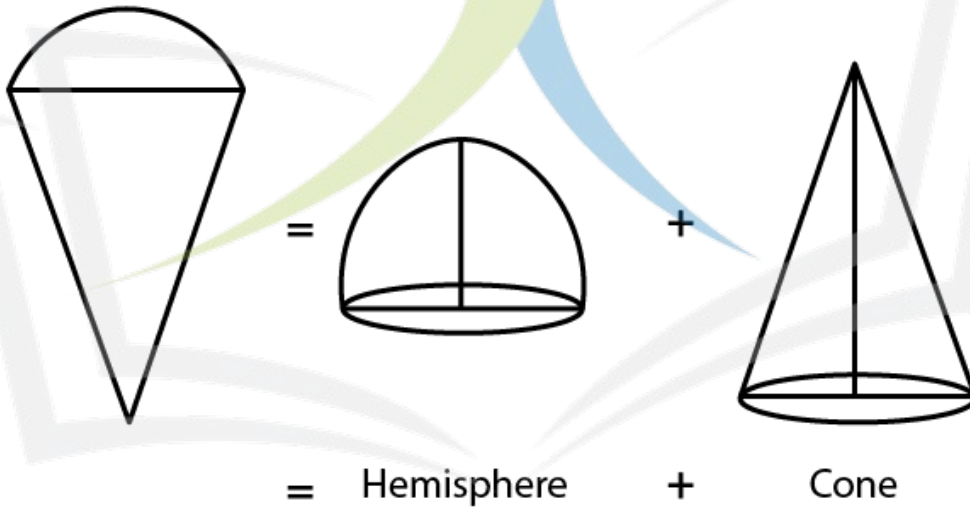

Fig. 12.2

- (A) a cone and a cylinder (B) a hemisphere and a cone
(C) frustum of a cone and a cylinder (D) sphere and cylinder

Solution:

(B) a hemisphere and a cone



The upper part of plumline = hemispherical,
The bottom part of plumline = conical
Therefore, it is a combination of hemisphere and cone.

4. The shape of a glass (tumbler) (see Fig. 12.3) is usually in the form of _____



Fig. 12.3

- (A) a cone
- (C) a cylinder

- (B) frustum of a cone
- (D) a sphere

Solution:

(B) frustum of a cone



The shape of glass is a frustum or specifically, an inverted frustum.

5. The shape of a *gilli*, in the *gilli-danda* game (see Fig. 12.4), is a combination of



Fig. 12.4

- (A) two cylinders
- (C) two cones and a cylinder

- (B) a cone and a cylinder
- (D) two cylinders and a cone

Solution:

(C) two cones and a cylinder

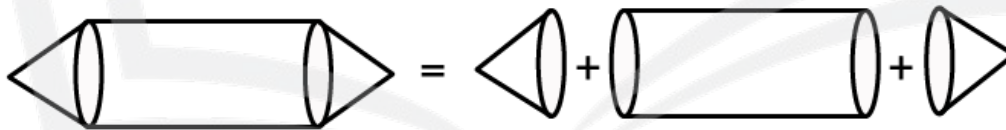

The left and right part of a gilli = conical

The central part of a gilli = cylindrical

Therefore, it is a combination of a cylinder and two cones.

6. A shuttle cock used for playing badminton has the shape of the combination of

- (A) a cylinder and a sphere
- (B) a cylinder and a hemisphere
- (C) a sphere and a cone
- (D) frustum of a cone and a hemisphere

Solution:

(D) frustum of a cone and a hemisphere

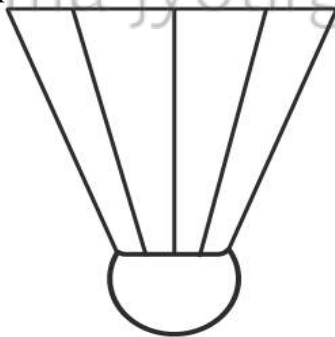

The cork of a shuttle = hemispherical shapes
 The upper part of a shuttle = shape of frustum of a cone.
 Therefore, it is a combination of frustum of a cone and a hemisphere.

7. A cone is cut through a plane parallel to its base and then the cone that is formed on one side of that plane is removed. The new part that is left over on the other side of the plane is called

- (A) a frustum of a cone (B) cone
 (C) cylinder (D) sphere

Solution:

(A) a frustum of a cone

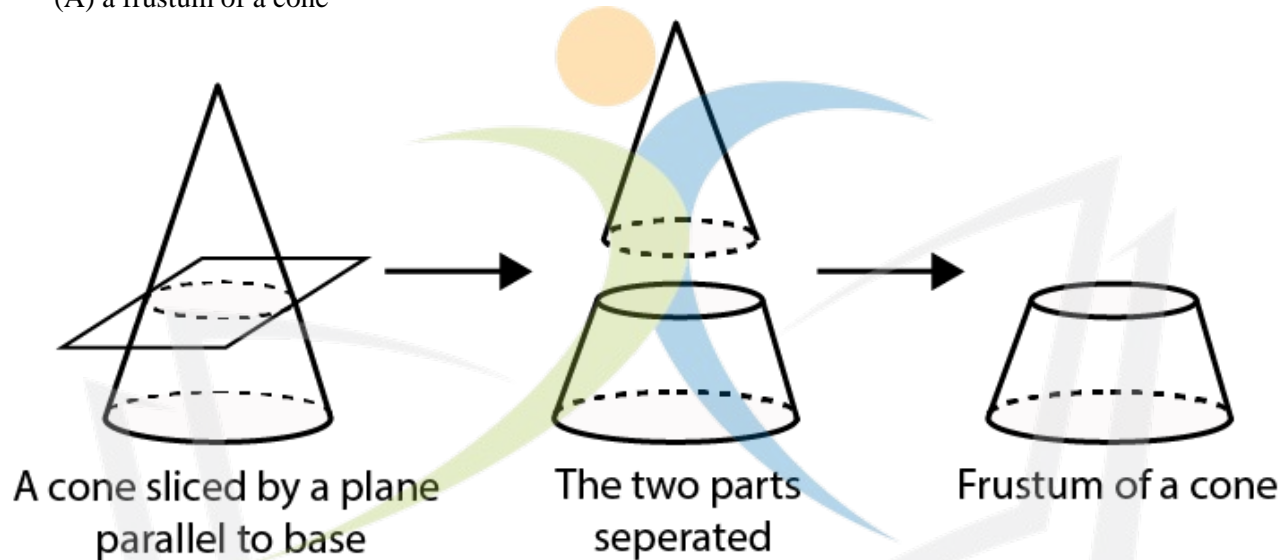

When a cone is divided into two parts by a plane through any point on its axis parallel to its base, the upper and lower parts obtained are cone and a frustum respectively.

8. A hollow cube of internal edge 22cm is filled with spherical marbles of diameter 0.5 cm and it is assumed that 1/8 space of the cube remains unfilled. Then the number of marbles that the cube can accommodate is

- (A) 142296 (B) 142396
 (C) 142496 (D) 142596

Solution:

(A) 142296

According to the question,

$$\text{Volume of cube} = 22^3 = 10648 \text{ cm}^3$$

$$\text{Volume of cube that remains unfilled} = \frac{1}{8} \times 10648 = 1331 \text{ cm}^3$$

$$\text{volume occupied by spherical marbles} = 10648 - 1331 = 9317 \text{ cm}^3$$

$$\text{Radius of the spherical marble} = \frac{0.5}{2} = 0.25 \text{ cm} = \frac{1}{4} \text{ cm}$$

$$\text{Volume of 1 spherical marble} = \frac{4}{3} \times \frac{22}{7} \times \left(\frac{1}{4}\right)^3 = \frac{11}{168} \text{ cm}^3$$

$$\text{Numbers of spherical marbles, } n = 9317 \times \left(\frac{11}{168}\right) = 142296$$

9. A metallic spherical shell of internal and external diameters 4 cm and 8 cm, respectively is melted and recast into the form a cone of base diameter 8cm. The height of the cone is

- (A) 12cm (B) 14cm (C) 15cm (D) 18cm

Solution:

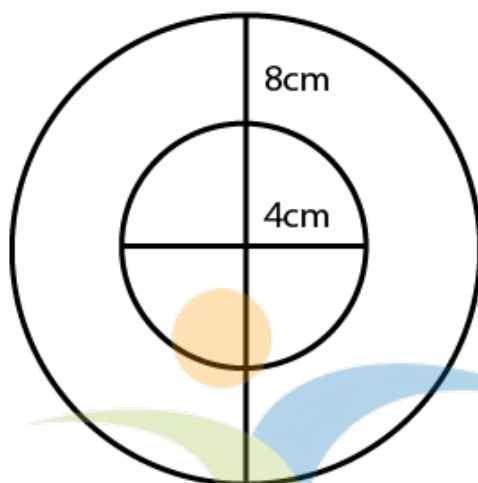

Spherical shell

Volume of spherical shell = Volume of cone recast by melting

For Spherical Shell,

Internal diameter, $d_1 = 4$ cm

Internal radius, $r_1 = 2$ cm

[as radius = $1/2$ diameter]

External diameter, $d_2 = 8$ cm

External radius, $r_2 = 4$ cm

Now,

As volume of spherical shell = $\frac{4}{3} \pi (r_2^3 - r_1^3)$

where r_1 and r_2 are internal and external radii respectively.

volume of given shell = $\frac{4}{3} \pi (4^3 - 2^3)$

$$= \frac{4}{3} \pi (56)$$

$$= (224/3) \pi$$

We know that,

Volume of cone = $224\pi / 3$ cm³

For cone,

Base diameter = 8 cm

Base radius, $r = 4$ cm

Let Height of cone = 'h'.

We know,

Volume of cone = $(1/3) \pi r^2 h$.

Where r = Base radius and h = height of cone

Volume of given cone = $(1/3) \pi 4^2 h$

$$\Rightarrow 224\pi / 3 = 16\pi h / 3$$

$$\Rightarrow 16h = 224$$

$$h = 14 \text{ cm}$$

So, Height of cone is 14 cm.

10. A solid piece of iron in the form of a cuboid of dimensions 49cm × 33cm × 24cm, is moulded to form a solid sphere. The radius of the sphere is

(A) 21cm (B) 23cm (C) 25cm (D) 19cm

Solution:

As we know,

Volume of cuboid = lbh

Where, l = length, b = breadth and h = height

For given cuboid,

Length, $l = 49$ cm

Breadth, $b = 33$ cm

Height, $h = 24$ cm

Volume of cube = $49 \times (33) \times (24)$ cm³

Now,

Let the radius of cube be r .

As volume of sphere = $\frac{4}{3} \pi r^3$

Where r = radius of sphere

Also,

Volume of cuboid = volume of sphere molded

So,

$$49(33)(24) = \frac{4}{3} \pi r^3$$

$$\Rightarrow \pi r^3 = 29106$$

$$\Rightarrow r^3 = 29106 \times \frac{22}{7}$$

$$\Rightarrow r^3 = 9261$$

$$\Rightarrow r = \sqrt[3]{9261} \text{ cm} = 21 \text{ cm}$$

Hence, radius of sphere is 21 cm

EXERCISE 12.2

Write 'True' or 'False' and justify your answer in the following:

1. Two identical solid hemispheres of equal base radius r cm are stuck together along their bases. The total surface area of the combination is $6\pi r^2$.

Solution:

False

Explanation:

When two hemispheres are joined together along their bases, a sphere of same base radius is formed.

Curved Surface Area of a sphere = $4\pi r^2$.

2. A solid cylinder of radius r and height h is placed over other cylinder of same height and radius. The total surface area of the shape so formed is $4\pi rh + 4\pi r^2$.

Solution:

False

Explanation:

According to the question,

When one cylinder is placed over another, the base of first cylinder and top of other cylinder will not be covered in total surface area.

We know that,

Total surface area of cylinder = $2\pi rh + 2\pi r^2$, where r = base radius and h = height

Total surface area of shape formed = $2(\text{Total surface of single cylinder}) - 2(\text{Area of base of cylinder})$

$$= 2(2\pi rh + 2\pi r^2) - 2(\pi r^2)$$

$$= 4\pi rh + 2\pi r^2$$

3. A solid cone of radius r and height h is placed over a solid cylinder having same base radius and height as that of a cone. The total surface area of the combined solid is $\pi r[\sqrt{r^2 + h^2} + 3r + 2h]$.

Solution:

False

Explanation:

When a solid cone is placed over a solid cylinder of same base radius, the base of cone and top of the cylinder will not be covered in total surface area.

Since the height of cone and cylinder is same,

We get,

Total surface area of cone = $\pi rl + \pi r^2$, where r = base radius and l = slant height

Total surface area of shape formed = Total surface area of cone + Total Surface area of cylinder - $2(\text{Area of base})$



Total surface area of cylinder = $2\pi rh + 2\pi r^2$, where r = base radius and h = height

$$\begin{aligned}
&= \pi r(r + l) + (2\pi r h + 2\pi r^2) - 2(\pi r^2) \\
&= \pi r^2 + \pi r l + 2\pi r h + 2\pi r^2 - 2\pi r^2 \\
&= \pi r(r + l + h) \\
&= \pi r(r + \sqrt{r^2 + h^2} + 2h) = \pi r(\sqrt{r^2 + h^2} + r + h)
\end{aligned}$$

4. A solid ball is exactly fitted inside the cubical box of side a . The volume of the ball is $4/3\pi a^3$.

Solution:

False

Explanation:

Let the radius of sphere = r

When a solid ball is exactly fitted inside the cubical box of side a ,

We get,

Diameter of ball = Edge length of cube

$$2r = a$$

$$\text{Radius, } r = a/2$$

We also know that,

$$\text{Volume of sphere} = 4/3\pi r^3$$

$$\text{Volume of ball} = 4/3\pi(a/2)^3 = 4/3\pi(a^3/8) = 1/6\pi a^3$$



NAGEEN GROUP
tamso ma jyotirgamaya

EXERCISE 12.3

1. Three metallic solid cubes whose edges are 3 cm, 4 cm and 5 cm are melted and formed into a single cube. Find the edge of the cube so formed.

Solution:

We know that,

Volume of cube = a^3 , where a = side of cube

According to the question,

Side of first cube, $a_1 = 3$ cm

Side of second cube, $a_2 = 4$ cm

Side of third cube, $a_3 = 5$ cm

Let us assume that the side of cube recast from melting these cubes = a

We know that the total volume of the 3 cubes will be the same as the volume of the newly formed cube,

Volume of new cube = (volume of 1st + 2nd + 3rd cube)

$$\Rightarrow a^3 = a_1^3 + a_2^3 + a_3^3$$

$$\Rightarrow a^3 = (3)^3 + (4)^3 + (5)^3$$

$$\Rightarrow a^3 = 27 + 64 + 125 = 216$$

$$\Rightarrow a = 6 \text{ cm}$$

Therefore, side of cube so formed is 6 cm.

2. How many shots each having diameter 3 cm can be made from a cuboidal lead solid of dimensions 9cm × 11cm × 12cm?

Solution:

Volume of cuboid = $l b h$, where, l = length, b = breadth and h = height

Cuboidal lead:

Length, $l = 9$ cm

Breadth, $b = 11$ cm

Height, $h = 12$ cm

Volume of lead = $9(11)(12) = 1188 \text{ cm}^3$

Volume of sphere = $\frac{4}{3}\pi r^3$, where r = radius of sphere

Spherical shots,

Diameter = 3 cm

Radius, $r = 1.5$ cm

Volume of one shot = $\frac{4}{3} \times \frac{22}{7} \times (1.5)^3 = \frac{99}{7} \text{ cm}^3$

$$\text{No. of shots can be made} = \frac{\text{Volume of lead}}{\text{Volume of one shot}} = \frac{1188}{\frac{99}{7}} = \frac{1188 \times 7}{99} = 84$$

Hence, the number of bullets that can be made from lead = 84.

3. A bucket is in the form of a frustum of a cone and holds 28.490 litres of water. The radii of the top and bottom are 28 cm and 21 cm, respectively. Find the height of the bucket.

Solution:

According to the question,

The bucket is in the form of frustum of a cone.

We know that,

Volume of frustum of a cone = $\frac{1}{3} \pi h (r_1^2 + r_2^2 + r_1 r_2)$, where, h = height, r_1 and r_2 are the radii ($r_1 > r_2$)

For bucket,

Volume of bucket = 28.490 L

1 L = 1000 cm^3

Volume of bucket = 28490 cm^3

Radius of top, $r_1 = 28$ cm

Radius of bottom, $r_2 = 21$ cm

Let the height = h .

Substituting these values in the equation to find the volume of bucket,

We have.

Volume of bucket = $\frac{1}{3} \pi h [28^2 + 21^2 + 28(21)]$

$28490 = \frac{1}{3} \times \frac{22}{7} \times h (784 + 441 + 588) = \frac{22}{7} \times h \times 1813$

$\Rightarrow h = (28490 \times 21) / (22 \times 1813)$

$\Rightarrow h = 15$

4. A cone of radius 8 cm and height 12 cm is divided into two parts by a plane through the mid-point of its axis parallel to its base. Find the ratio of the volumes of two parts.

Solution:

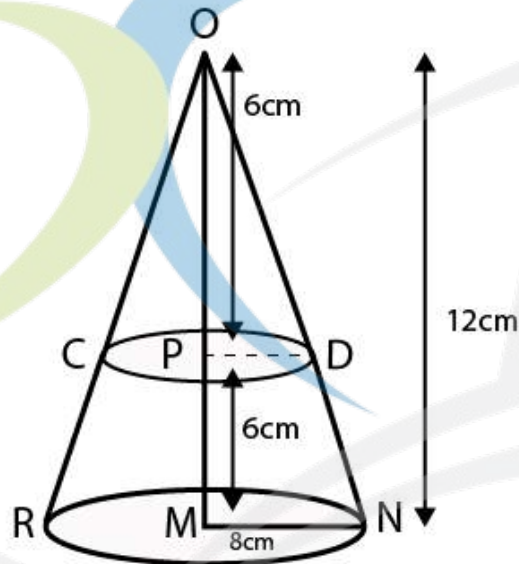

According to the question,

Height of cone = $OM = 12$ cm

The cone is divided from mid-point.

Hence, let the mid-point of cone = P

$OP = PM = 6$ cm

From $\triangle OPD$ and $\triangle OMN$

$\angle POD = \angle POM$ [Common]

$\angle OPD = \angle OMN$ [Both 90°]

Hence, by the Angle-Angle similarity criterion

We have,

$\triangle OPD \sim \triangle OMN$

And

Similar triangles have corresponding sides in equal ratio,

So, we have,

$PD/MN = OP/OM$

$PD/8 = 6/12$

$PD = 4$ cm

[$MN = 8$ cm = radius of base of cone]

For First part i.e. cone

Base Radius, $r = PD = 4$ cm

Height, $h = OP = 6$ cm

We know that,

Volume of cone for radius r and height h , $V = \frac{1}{3} \pi r^2 h$

Volume of first part = $\frac{1}{3} \pi (4)^2 6 = 32\pi$

For second part, i.e. Frustum

Bottom radius, $r_1 = MN = 8$ cm

Top Radius, $r_2 = PD = 4$ cm

Height, $h = PM = 6$ cm

We know that,

Volume of frustum of a cone = $\frac{1}{3} \pi h (r_1^2 + r_2^2 + r_1 r_2)$, where, h = height, r_1 and r_2 are radii, ($r_1 > r_2$)

Volume of second part = $\frac{1}{3} \pi (6) [8^2 + 4^2 + 8(4)]$
 $= 2\pi(112) = 224\pi$

Therefore, we get the ratio,

Volume of first part : Volume of second part = $32\pi : 224\pi = 1 : 7$

5. Two identical cubes each of volume 64 cm^3 are joined together end to end. What is the surface area of the resulting cuboid?

Solution:

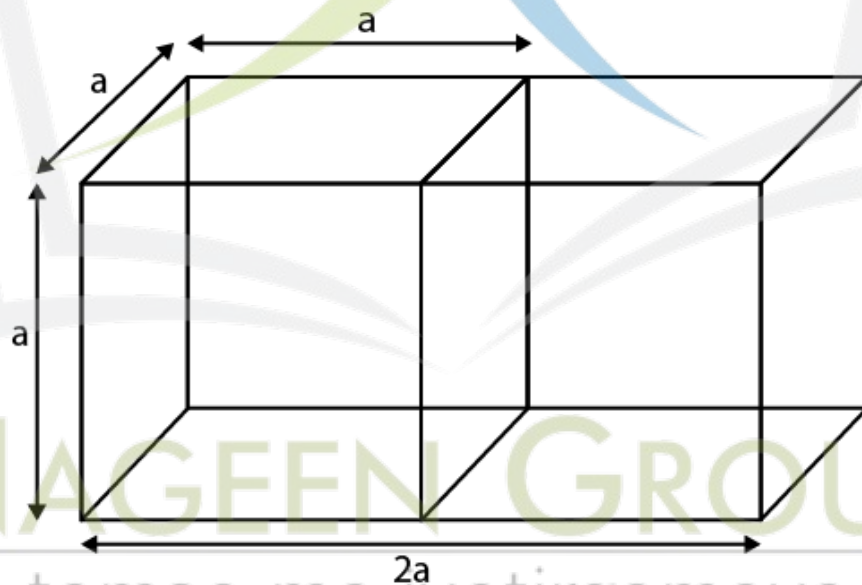

Let the side of one cube = a

Surfaces area of resulting cuboid = $2(\text{Total surface area of a cube}) - 2(\text{area of single surface})$

We know that,

Total surface area of cube = $6a^2$, where a = side of cube

\Rightarrow Surfaces area of resulting cuboid = $2(6a^2) - 2(a^2) = 10a^2$

Also,

According to the question,

Volume of cube = 64 cm^3

Volume of cube = a^3

$64 = a^3$

$$a = 4 \text{ cm}$$

Therefore,

$$\text{Surface area of resulting cuboid} = 10a^2 = 10(4)^2 = 160 \text{ cm}^2$$

6. From a solid cube of side 7 cm, a conical cavity of height 7 cm and radius 3 cm is hollowed out. Find the volume of the remaining solid.

Solution:

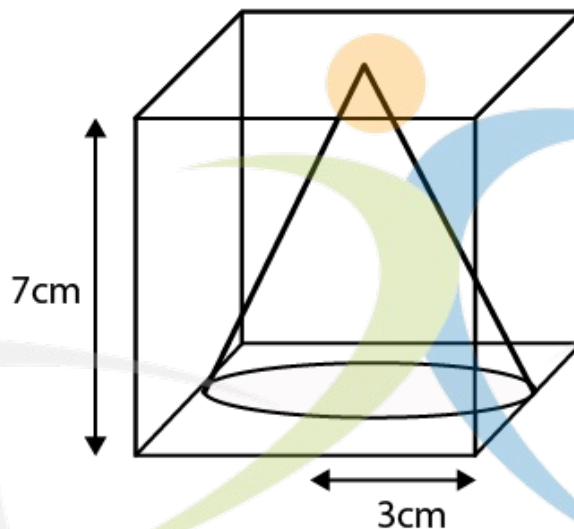

From the figure, we get,

Volume of remaining solid = volume of cube - volume of cone

For Cube

Side, $a = 7 \text{ cm}$

We know that,

Volume of cube = a^3 , where $a =$ side of cube

$$\text{Volume of cube} = (7)^3 = 343 \text{ cm}^3$$

For cone

Radius, $r = 3 \text{ cm}$

Height, $h = 7 \text{ cm}$

$$\text{Volume of cone} = \frac{1}{3} \pi r^2 h = \frac{1}{3} \pi (3)^2 7 = 3 \times \left(\frac{22}{7}\right) \times 7 = 66 \text{ cm}^3$$

Volume of remaining solid = volume of cube - volume of cone

$$= 343 - 66$$

$$= 277 \text{ cm}^3$$

7. Two cones with same base radius 8 cm and height 15 cm are joined together along their bases. Find the surface area of the shape so formed.

Solution:

According to the question,

We get the figure given below,

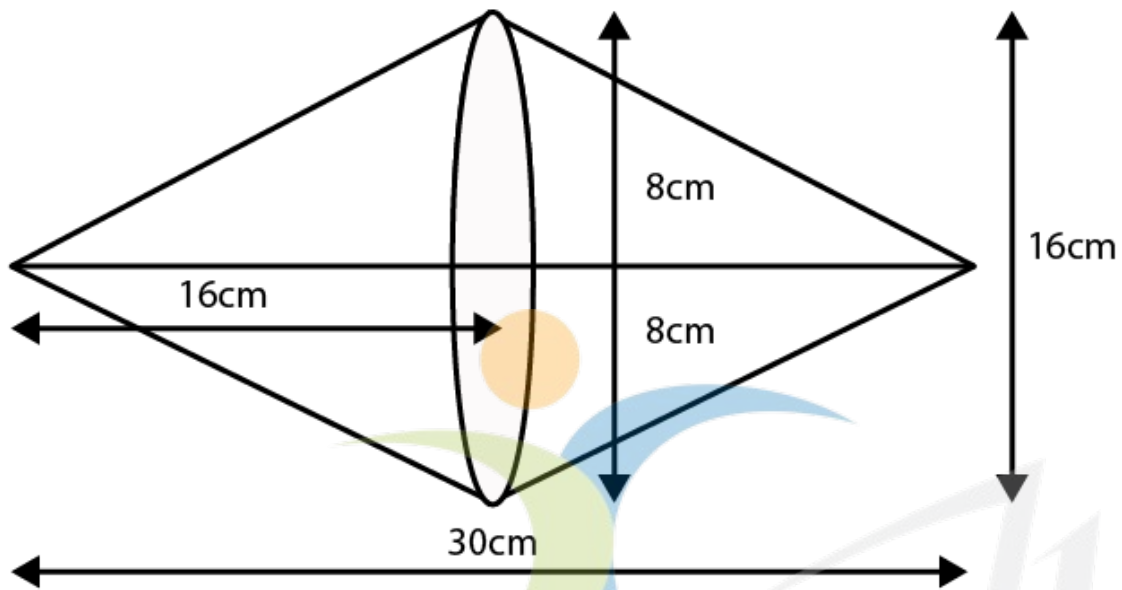

We know that,

Total surface area of shape formed = Curved area of first cone + Curved surface area of second cone

Since, both cones are identical,

We have,

Total surface area of shape formed = Curved area of first cone + Curved surface area of second cone
 $= 2(\text{Surface area of cone})$

We also know that,

Surface area of cone = $\pi r l$, where r = radius and l = slant height

And, the total Surface area of shape so formed = $2\pi r l$

Given in the question that,

Radius, $r = 8$ cm

Height, $h = 15$ cm

Therefore,

Area = $2(3.14)(8)(15) = 753.6 \text{ cm}^2$

NAGEEN GROUP
 tamso ma jyotirgamaya

EXERCISE 12.4

1. A solid metallic hemisphere of radius 8 cm is melted and recasted into a right circular cone of base radius 6 cm. Determine the height of the cone.

Solution:

For hemisphere,

Radius, $r = 8$ cm

We know that,

Volume of hemisphere = $\frac{2}{3} \pi r^3$, where, $r =$ radius of hemisphere

So, we get,

Volume of given hemisphere = $\frac{2}{3} \times \pi \times 8^3 = \frac{1024}{3} \pi \text{ cm}^3$

Now,

For the cone that is recast from a hemisphere,

Base radius, $r = 6$ cm

We also know that,

Volume of cone = $\frac{1}{3} \pi r^2 h$, where, r is base radius and h is the height of the cone.

So, we get,

Volume of cone = $\frac{1}{3} \pi (6)^2 h = 12\pi h$

According to the question, we know that,

The volume remains same, when a body is reformed to another body
Volume of cylinder = Volume of cone

$12\pi h = 1024\pi / 3$

$h = 28.44$ cm

2. A rectangular water tank of base 11 m \times 6 m contains water upto a height of 5 m. If the water in the tank is transferred to a cylindrical tank of radius 3.5 m, find the height of the water level in the tank.

Solution:

Volume of water in tank = volume of cuboidal tank up to a height of 5 m

According to the question,

For cuboidal tank

Length, $l = 11$ m

Breadth, $b = 6$ m

Height, $h = 5$ m

We know that the equation to find the volume of the tank,

Volume of tank = lbh , where, l , b and h are the length, breadth and height of tank respectively

Volume of water = $11(6)(5) = 330 \text{ m}^3$

We also know that,

Base radius of cylindrical tank, $r = 3.5$ m

Let the height till which the cylindrical tank is filled = h m

Hence, using the formula,

Volume of a cylinder = $\pi r^2 h$, where r is base radius and h is the height of cylinder

Volume of water in cylindrical tank = $\pi (3.5)^2 h$

$330 \text{ m}^3 = \frac{22}{7} \times 3.5 \times 3.5 \times h = 38.5 \times$

$h = 8.57$ m

Hence, the height till which the cylindrical tank is filled = 8.57 m

3. How many cubic centimetres of iron is required to construct an open box whose external dimensions are 36 cm, 25 cm and 16.5 cm provided the thickness of the iron is 1.5 cm. If one cubic cm of iron weighs 7.5 g, find the weight of the box.

Solution:

Let the length (l), breadth (b), and height (h) be the external dimension of an open box and thickness be x .

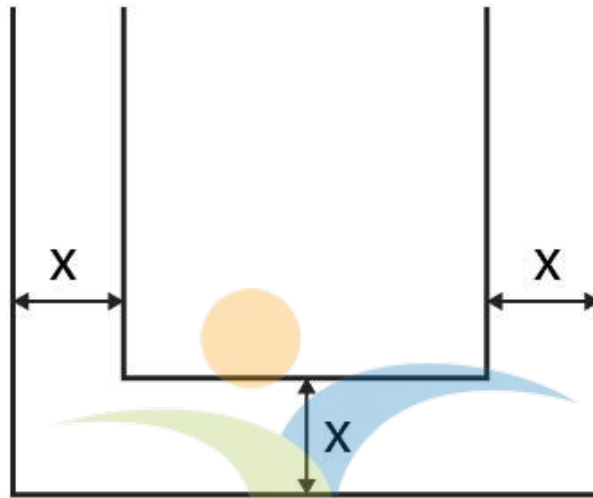

The volume of metal used in box = Volume of external box - Volume of internal box

Consider external box,

Length, $l = 36$ cm

Breadth, $b = 25$ cm

Height, $h = 16.5$ cm

We know that the equation of the volume of cuboid is given by,

Volume of cuboid = lbh , where, l , b and h are the length, breadth and height of tank respectively

Volume of external box = $36(25)(16.5) = 14850$ cm³

Since the box is open from top,

Consider internal box,

The thickness of two sides is reduced as follows,

Length, $l' =$ Length of external box - $2(\text{thickness of box}) = 36 - 2(1.5) = 33$ cm

Breadth, $b' =$ Breadth of external box - $2(\text{thickness of box}) = 25 - 2(1.5) = 22$ cm

Height, $h' =$ Height of external box - thickness of box = $16.5 - 1.5 = 15$ cm

Volume of internal box = $33(22)(15) = 10890$

And,

Volume of metal in box = $14850 - 10890 = 3960$ cm³

We know that,

1 cm³ weighs 7.5 g

So, 3960 cm³ weighs $3960(7.5) = 29,700$ g

Therefore, the weight of box is $29,700$ g i.e. 29.7 kg

4. The barrel of a fountain pen, cylindrical in shape, is 7 cm long and 5 mm in diameter. A full barrel of ink in the pen is used up on writing 3300 words on an average. How many words can be written in a bottle of ink containing one fifth of a litre?

Solution:

Let us first calculate the volume of barrel of pen that is of cylindrical shape

Consider barrel,

Since 1 cm = 10 mm

Base diameter = 5 mm = 0.5 cm

Base radius, $r = 0.25$ cm

Height, $h = 7$ cm

We know that,

Volume of a cylinder = $\pi r^2 h$

Volume of barrel = $\pi (0.25)^2 7$

Volume of barrel = $22/7 \times 0.25 \times 0.25 \times 7 = 1.375$ cm³

Hence, according to the question,

1.375 cm³ of ink can write 3300 words

No of words that can be written by 1 cm³ of ink = $3300/1.375 = 2400$ words

1/5th of a liter = 0.2 L

We know that,

1 L = 1000 cm³

0.2 L = 200 cm³

So, no of words that can be written by 200 cm³ = $2400(200) = 480000$ words

Therefore, 1/5th of a liter ink can write 480000 words.

5. Water flows at the rate of 10m/minute through a cylindrical pipe 5 mm in diameter. How long would it take to fill a conical vessel whose diameter at the base is 40 cm and depth 24 cm?

Solution:

Let the time taken by pipe to fill vessel = t minutes

Since water flows 10 m in 1 minute, it will flow $10t$ meters in t minutes.

According to the question,

Volume of conical vessel = Volume of water that passes through pipe in t minutes

Consider conical pipe

Base Diameter = 40 cm

Base radius, $r = 20$ cm

Height, $h = 24$ cm

We know that the volume of cone = $1/3\pi r^2 h$

Volume of conical vessel = $1/3\pi(20)^2(24) = 3200 \pi$ cm³

Consider cylindrical pipe

Base diameter = 5 mm = 0.5 cm

Base radius, $r = 0.25$ cm

Water covers $10t$ m distance in pipe,

Hence, we get,

Height, $h = 10t$ m = $1000t$ cm

We also know that,

Volume of a cylinder = $\pi r^2 h$

Volume of water passed in pipe = $\pi(0.25)^2(1000t) = 62.5t\pi$ cm³

So, we have

$62.5t\pi = 3200$

$62.5t = 3200$

$t = 51.2$ minutes

We know that,

0.2 minutes = $0.2(60)$ seconds = 12 seconds

Therefore, $t = 51$ minutes 12 seconds

6. A heap of rice is in the form of a cone of diameter 9 m and height 3.5 m. Find the volume of the rice. How much canvas cloth is required to just cover the heap?

Solution:

According to the question,
 Consider conical heap,
 Base Diameter = 9 cm
 So, base radius, $r = 4.5$ cm
 Height, $h = 3.5$ cm
 We know that,
 Slant height,

$$l = \sqrt{r^2 + h^2}$$

$$\Rightarrow \sqrt{(4.5)^2 + (3.5)^2} = \sqrt{20.25 + 12.25}$$

$$\Rightarrow l = \sqrt{32.5} = 5.7 \text{ cm}$$

The equation of volume of cone = $\frac{1}{3}\pi r^2 h$
 We know that,

Volume of rice = Volume of conical heap
 Volume of rice = $\frac{1}{3}\pi(4.5)^2(3.5)$

$$\Rightarrow \text{Volume of rice} = \frac{1}{3} \times \frac{22}{7} \times 4.5 \times 4.5 \times 3.5 = 74.25 \text{ cm}^3$$

We also know that,

Canvas requires to just cover heap = Curved surface area of conical heap

And curved surface area of a cone = $\pi r l$

Therefore, the canvas required = $\pi(4.5)(5.7) = 80.61 \text{ cm}^2$ [appx]

7. A factory manufactures 120000 pencils daily. The pencils are cylindrical in shape each of length 25 cm and circumference of base as 1.5 cm. Determine the cost of colouring the curved surfaces of the pencils manufactured in one day at Rs 0.05 per dm^2 .

Solution:

The shape of pencil = cylinder.

Let the radius of base = r cm

Circumference of base = 1.5 cm

Circumference of circle is $2\pi r = 1.5$ cm

$$r = 1.5/2\pi \text{ cm}$$

According to the question,

Height, $h = 25$ cm

We know that,

Curved surface area of cylinder = $2\pi r h$

$$\text{Curved surface area of pencil} = 2\pi (1.5/2\pi) 25 = 37.5 \text{ cm}^2$$

$$1 \text{ cm} = 0.1 \text{ dm}$$

$$1 \text{ cm}^2 = 0.01 \text{ dm}^2$$

$$37.5 \text{ cm}^2 = 0.375 \text{ dm}^2$$

$$\text{Cost for coloring } 1 \text{ dm}^2 = \text{Rs. } 0.05$$

$$\text{Cost for coloring } 0.375 \text{ dm}^2 \text{ (i.e. 1 pencil)} = \text{Rs. } 0.01875$$

$$\text{Cost for coloring 120000 pencils} = 120000 \times 0.01875 = \text{Rs. } 2250$$

8. Water is flowing at the rate of 15 km/h through a pipe of diameter 14 cm into a cuboidal pond which is 50 m long and 44 m wide. In what time will the level of water in pond rise by 21 cm?

Solution:

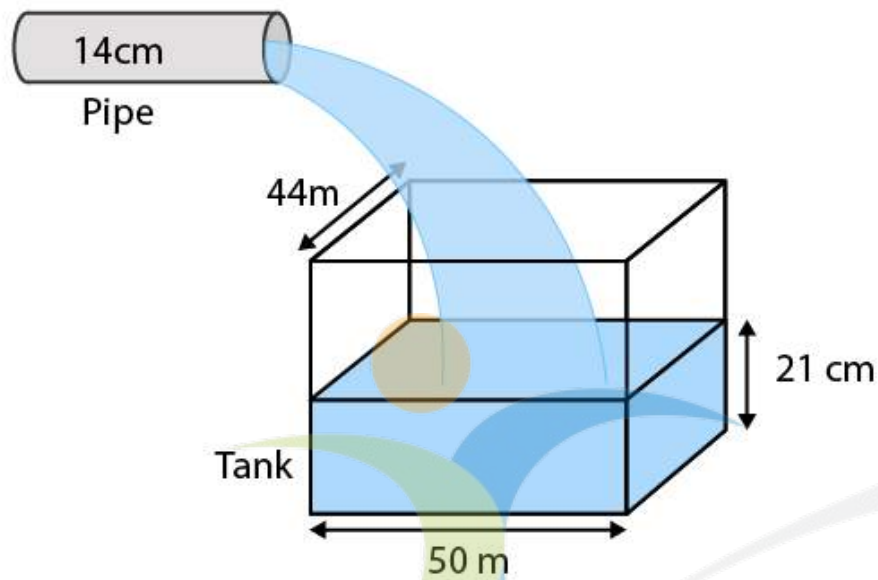

Let the time taken by pipe to fill pond = t hours

Water flows 15 km in 1 hour, so, it will flow $15t$ meters in t hours.

We know that,

Volume of cuboidal pond up to height 21 cm = Volume of water that passes through pipe in " t " hours

Considering cuboidal pond,

Length, $l = 50$ m

Breadth, $b = 44$ m

Height, $h = 21$ cm = 0.21 m

We know that,

Volume of tank = lbh

Volume of water = $50(44)(0.21) = 462$ m³

Considering cylindrical pipe

Base diameter = 14 cm

Base radius, $r = 7$ cm = 0.07 m

Height, $h = 15t$ km = $15000t$ m

We also know that,

Volume of a cylinder = $\pi r^2 h$

Volume of water passed in pipe = $\pi(0.07)^2(15000t)$

$= \frac{22}{7} \times 0.07 \times 0.07 \times 15000t$

$= 231t$ m³

So, we have

$231t = 462$

$t = 2$ hours

Time required to fill tank up to a height of 25 cm is 2 hours.

9. A solid iron cuboidal block of dimensions 4.4 m × 2.6 m × 1m is recast into a hollow cylindrical pipe of internal radius 30 cm and thickness 5 cm. Find the length of the pipe.

Solution:

Considering cuboidal block

Length, $l = 4$ m

Breadth, $b = 2.6$ m

Height, $h = 1$ m

We know that,

Volume of tank = lbh

Volume of cuboid = $4.4(2.6)(1) = 11.44 \text{ m}^3$

We know that,

The volume remains same when a body is recast to another body.

According to the question,

Volume of cylindrical pipe = 11.44 m^3

Considering pipe or the hollow cylinder

Internal radius, $r_2 = 30 \text{ cm} = 0.3 \text{ m}$

Thickness = 5 cm

External radius, $r_1 = \text{Internal radius} + \text{thickness} = 30 + 5 = 35 \text{ cm} = 0.35 \text{ m}$

Let the length of pipe = h

We know that,

Volume of a hollow cylinder = $\pi h(r_1^2 - r_2^2)$

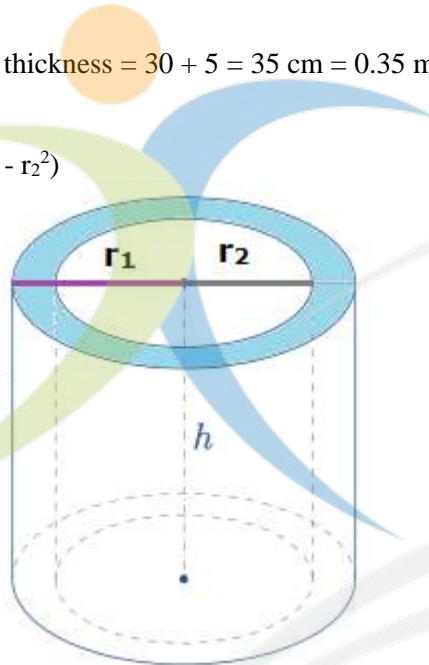

Hence,

Volume of pipe = $\pi h((0.35)^2 - (0.3)^2)$

$$\Rightarrow 11.44 = \frac{22}{7} \times h \times 0.0325$$

$$\Rightarrow h = \frac{11.44 \times 7}{22 \times 0.0325} = 112 \text{ m}$$

So, the length of pipe is 112 m .

10. 500 persons are taking a dip into a cuboidal pond which is 80 m long and 50 m broad. What is the rise of water level in the pond, if the average displacement of the water by a person is 0.04 m^3 ?

Solution:

According to the question,

Average displacement by a person = 0.04 m^3

Average displacement by 500 persons = $500 \times 0.04 = 20 \text{ m}^3$

Hence, the volume of water raised in pond = 20 m^3

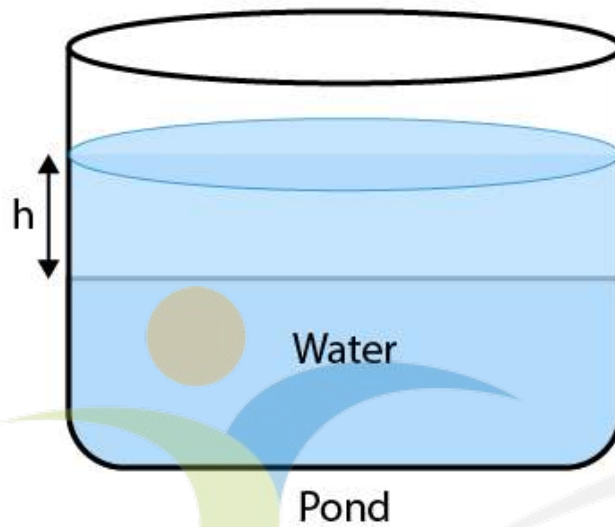

It is also given that,
Length of pond, $l = 80$ m
Breadth of pond, $b = 50$ m
Height = h
Volume of water raised in pond = $80(50)(h)$
 $20 \text{ m}^3 = 4000h$
 $h = 0.005 \text{ m} = 0.5 \text{ cm}$
Therefore, raise in the height of water = 0.5 cm .

NAGEEN GROUP
tamso ma jyotirgamaya

ANIMATED VIDEOS FOR CLASS 10

(Subject: Mathematics in English Language)

- Chapter: Area Related to Circles [Click here to view animated video](#)
- Chapter: Arithmetic Progressions [Click here to view animated video](#)
- Chapter: Circles [Click here to view animated video](#)
- Chapter: Coordinate Geometry [Click here to view animated video](#)
- Chapter: Constructions (Deleted 2023-24) [Click here to view animated video](#)
- Chapter: Pair of Linear Equations in Two Variables [Click here to view animated video](#)
- Chapter: Polynomials [Click here to view animated video](#)
- Chapter: Probability [Click here to view animated video](#)
- Chapter: Quadratic Equations [Click here to view animated video](#)
- Chapter: Real Numbers I [Click here to view animated video](#)
- Chapter: Real Numbers II [Click here to view animated video](#)
- Chapter: Some Applications of Trigonometry [Click here to view animated video](#)
- Chapter: Statistics [Click here to view animated video](#)
- Chapter: Surface Areas and Volumes [Click here to view animated video](#)
- Chapter: Triangles [Click here to view animated video](#)
- Chapter: Trigonometric Identities [Click here to view animated video](#)
- Chapter: Trigonometric Ratios [Click here to view animated video](#)

ANIMATED VIDEOS FOR CLASS 10

Subject: Science (Physics in English Language)

- Chapter: Electricity [Click here to view animated video](#)
- Chapter: Human Eye and Colorful World [Click here to view animated video](#)
- Chapter: Light Reflection and Refraction I [Click here to view animated video](#)
- Chapter: Light Reflection and Refraction II [Click here to view animated video](#)
- Chapter: Magnetism Effects of Electric Current [Click here to view animated video](#)
- Chapter: Sources of Energy (Deleted 2023-24) [Click here to view animated video](#)

ANIMATED VIDEOS FOR CLASS 10

Subject: Science (Chemistry in English Language)

- Chapter: Acids, Bases and Salts [Click here to view animated video](#)
- Chapter: Carbon and its compounds [Click here to view animated video](#)
- Chapter: Chemical Reactions and Equations [Click here to view animated video](#)
- Chapter: Metals and Non Metals [Click here to view animated video](#)
- Chapter: Periodic Classification of Elements (Deleted 2023-24) [Click here to view animated video](#)

ANIMATED VIDEOS FOR CLASS 10

Subject: Science (Biology in English Language)

- Chapter: Control and Coordination II [Click here to view animated video](#)
- Chapter: Heredity (and Evolution Deleted 2023-24) I [Click here to view animated video](#)
- Chapter: Heredity (and Evolution Deleted 2023-24) II [Click here to view animated video](#)
- Chapter: How Do Organisms Reproduce I [Click here to view animated video](#)
- Chapter: How Do Organisms Reproduce II [Click here to view animated video](#)
- Chapter: How Do Organisms Reproduce III [Click here to view animated video](#)
- Chapter: How Do Organisms Reproduce IV [Click here to view animated video](#)
- Chapter: Life Processes Excretion (Deleted 2023-24) [Click here to view animated video](#)
- Chapter: Our Environment [Click here to view animated video](#)
- Chapter: Life Processes Transportation (Deleted 2023-24) [Click here to view animated video](#)
- Chapter: Management of Natural Resources (Deleted 2023-24) [Click here to view animated video](#)
- Chapter: Life Processes Transportation (Deleted 2023-24) [Click here to view animated video](#)
- Chapter: Chapter Life Processes I [Click here to view animated video](#)
- Chapter: Chapter Life Processes II [Click here to view animated video](#)
- Chapter: Control and Coordination [Click here to view animated video](#)

ANIMATED VIDEOS FOR CLASS 10

Subject: Social Science in English Language

- **Chapter: Real Numbers II** [Click here to view animated video](#)
- Chapter: Some Applications of Trigonometry [Click here to view animated video](#)
- Chapter: Statistics [Click here to view animated video](#)
- Chapter: Surface Areas and Volumes [Click here to view animated video](#)
- Chapter: Triangles [Click here to view animated video](#)
- Chapter: Trigonometric Identities [Click here to view animated video](#)
- Chapter: Trigonometric Ratios [Click here to view animated video](#)
- Chapter: Triangles – 1 [Click here to view animated video](#)

ANIMATED VIDEOS FOR CLASS 10

Subject: Science (Physics in Hindi Language)

- Chapter: Electricity [Click here to view animated video](#)
- Chapter: Human Eye and Colorful World [Click here to view animated video](#)
- Chapter: Light Reflection and Refraction I [Click here to view animated video](#)
- Chapter: Light Reflection and Refraction II [Click here to view animated video](#)
- Chapter: Magnetics Effects of Electric Current [Click here to view animated video](#)
- Chapter: Sources of Energy (Deleted 2023-24) [Click here to view animated video](#)

ANIMATED VIDEOS FOR CLASS 10

Subject: Science (Chemistry in Hindi Language)

- Chapter: Acids, Bases and Salts [Click here to view animated video](#)
- Chapter: Carbon and its compounds [Click here to view animated video](#)
- Chapter: Chemical Reactions and Equations [Click here to view animated video](#)
- Chapter: Metals and Non Metals [Click here to view animated video](#)
- Chapter: Periodic Classification of Elements (Deleted 2023-24) [Click here to view animated video](#)

ANIMATED VIDEOS FOR CLASS 10

Subject: Science (Biology in Hindi Language)

- Chapter: Control and Coordination II [Click here to view animated video](#)
- Chapter: Heredity (and Evolution Deleted 2023-24) I [Click here to view animated video](#)
- Chapter: Heredity (and Evolution Deleted 2023-24) II [Click here to view animated video](#)
- Chapter: How Do Organisms Reproduce I [Click here to view animated video](#)
- Chapter: How Do Organisms Reproduce II [Click here to view animated video](#)
- Chapter: How Do Organisms Reproduce III [Click here to view animated video](#)
- Chapter: How Do Organisms Reproduce IV [Click here to view animated video](#)
- Chapter: Life Processes Excretion (Deleted 2023-24) [Click here to view animated video](#)
- Chapter: Our Environment [Click here to view animated video](#)
- Chapter: Management of Natural Resources (Deleted 2023-24) [Click here to view animated video](#)
- Chapter: Life Processes Transportation (Deleted 2023-24) [Click here to view animated video](#)
- Chapter: Chapter Life Processes I [Click here to view animated video](#)
- Chapter: Chapter Life Processes II [Click here to view animated video](#)
- Chapter: Control and Coordination [Click here to view animated video](#)

Why Artham Resource Material?

Resource materials for teachers and students are essential tools for effective teaching and learning. They provide valuable information, guidance, and support to both teachers and students, making the teaching and learning process more efficient and productive.

For teachers, Artham resource materials include lesson plans, instructional guides, assessment tools, professional development materials, and teaching aids. These materials are well researched and created according to 2023-24 NEP and NCERT guidelines.

For students, resource materials can include textbooks, study guides, homework assignments, reference books, online learning platforms, and educational videos. These materials can be obtained from school libraries, educational publishers, online resources, and teachers.

Both teachers and students can also benefit from Artham educational resources which are free and openly licensed educational materials that can be used and shared for teaching and learning. Artham resource material include textbooks, courses, lesson plans, and multimedia resources that are available online.

In summary, resource materials are critical components of effective teaching and learning. They provide a wealth of information and support that can enhance the quality of education and help students achieve academic success.

Teachers and students can also purchase these resources from the links provided with every resource.

JOIN TELEGRAM GROUP/CHANNELS FOR CLASS WISE HIGH QUALITY RESOURCE MATERIAL

SOE CBSE Groups

- [Click to Join CBSE Group...All classes](#)
- [Click to Join SOE CBSE Kindergarten Group](#)
- [Click to Join SOE CBSE Class 1 Group](#)
- [Click to Join SOE CBSE Class 2 Group](#)
- [Click to Join SOE CBSE Class 3 Group](#)
- [Click to Join SOE CBSE Class 4 Group](#)
- [Click to Join SOE CBSE Class 5 Group](#)
- [Click to Join SOE CBSE Class 6 Group](#)
- [Click to Join SOE CBSE Class 7 Group](#)
- [Click to Join SOE CBSE Class 8 Group](#)
- [Click to Join SOE CBSE Class 9 Group](#)
- [Click to Join SOE CBSE Class 10 Group](#)
- [Click to Join SOE CBSE Class 11 \(Science\) Group](#)
- [Click to Join SOE CBSE Class 11 \(Commerce\) Group](#)
- [Click to Join SOE CBSE Class 11 \(Humanities\) Group](#)
- [Click to Join SOE CBSE Class 12 \(Science\) Group](#)
- [Click to Join SOE CBSE Class 12\(Commerce\) Group](#)

- [Click to Join SOE CBSE Class 12 \(Humanities\) Group](#)
- [Click to Join SOE JEE/NEET Group](#)
- [Click to Join SOE CUET Group](#)
- [Click to Join SOE NDA, OLYMPIAD, NTSE Group](#)
- [Click to Join SOE School Principal Professional Development Group](#)
- [Click to Join SOE School Teacher Professional Development Group](#)
- [Click to Join SOE CBSE Project File Group for Class 9th to 12th All Subjects](#)

SOE ICSE Groups

- [Click to Join SOE ICSE Kindergarten Group](#)
- [Click to Join SOE ICSE Class 1 Group](#)
- [Click to Join SOE ICSE Class 2 Group](#)
- [Click to Join SOE ICSE Class 3 Group](#)
- [Click to Join SOE ICSE Class 4 Group](#)
- [Click to Join SOE ICSE Class 5 Group](#)
- [Click to Join SOE ICSE Class 6 Group](#)
- [Click to Join SOE ICSE Class 7 Group](#)
- [Click to Join SOE ICSE Class 8 Group](#)
- [Click to Join SOE ICSE Class 9 Group](#)
- [Click to Join SOE ICSE Class 10 Group](#)
- [Click to Join SOE ICSE Class 11 \(Science\) Group](#)
- [Click to Join SOE ICSE Class 11 \(Commerce\) Group](#)
- [Click to Join SOE ICSE Class 11 \(Humanities\) Group](#)
- [Click to Join SOE ICSE Class 12 \(Science\) Group](#)
- [Click to Join SOE ICSE Class 12\(Commerce\) Group](#)
- [Click to Join SOE ICSE Class 12 \(Humanities\) Group](#)
- [Click to Join SOE JEE/NEET Group](#)
- [Click to Join SOE CUET Group](#)
- [Click to Join SOE NDA, OLYMPIAD, NTSE Group](#)
- [Click to Join SOE School Principal Professional Development Group](#)
- [Click to Join SOE School Teacher Professional Development Group](#)

Nageen CBSE Channels

- [Click to Join Nageen CBSE Kindergarten Channel](#)
- [Click to Join Nageen CBSE Class 1 Channel](#)
- [Click to Join Nageen CBSE Class 2 Channel](#)
- [Click to Join Nageen CBSE Class 3 Channel](#)
- [Click to Join Nageen CBSE Class 4 Channel](#)
- [Click to Join Nageen CBSE Class 5 Channel](#)
- [Click to Join Nageen CBSE Class 6 Channel](#)
- [Click to Join Nageen CBSE Class 7 Channel](#)
- [Click to Join Nageen CBSE Class 8 Channel](#)
- [Click to Join Nageen CBSE Class 9 Channel](#)
- [Click to Join Nageen CBSE Class 10 Channel](#)
- [Click to Join Nageen CBSE Class 11 \(Science\) Channel](#)
- [Click to Join Nageen CBSE Class 11 \(Humanities\) Channel](#)
- [Click to Join Nageen CBSE Class 11 \(Commerce\) Channel](#)
- [Click to Join Nageen CBSE Class 12 \(Science\) Channel](#)
- [Click to Join Nageen CBSE Class 12 \(Commerce\) Channel](#)
- [Click to Join Nageen CBSE Class 12 \(Humanities\) Channel](#)

- [Click to Join JEE/NEET Channel](#)
- [Click to Join CUET Channel](#)
- [Click to Join NDA, OLYMPIAD, NTSE Channel](#)

Nageen ICSE Channels

- [Click to Join Nageen ICSE Kindergarten Channel](#)
- [Click to Join Nageen ICSE Class 1 Channel](#)
- [Click to Join Nageen ICSE Class 2 Channel](#)
- [Click to Join Nageen ICSE Class 3 Channel](#)
- [Click to Join Nageen ICSE Class 4 Channel](#)
- [Click to Join Nageen ICSE Class 5 Channel](#)
- [Click to Join Nageen ICSE Class 6 Channel](#)
- [Click to Join Nageen ICSE Class 7 Channel](#)
- [Click to Join Nageen ICSE Class 8 Channel](#)
- [Click to Join Nageen ICSE Class 9 Channel](#)
- [Click to Join Nageen ICSE Class 10 Channel](#)
- [Click to Join Nageen ICSE Class 11 \(Science\) Channel](#)
- [Click to Join Nageen ICSE Class 11 \(Commerce\) Channel](#)
- [Click to Join Nageen ICSE Class 11 \(Humanities\) Channel](#)
- [Click to Join Nageen ICSE Class 12 \(Science\) Channel](#)
- [Click to Join Nageen ICSE Class 12 \(Commerce\) Channel](#)
- [Click to Join Nageen ICSE Class 12 \(Humanities\) Channel](#)
- [Click to Join JEE/NEET Channel](#)
- [Click to Join CUET Channel](#)
- [Click to Join NDA, OLYMPIAD, NTSE Channel](#)











SCHOOL OF EDUCATORS





You will get Pre- Board Papers PDF, Word file, PPT, Lesson Plan, Worksheet, practical tips and Viva questions , reference books , smart content , curriculum , syllabus , marking scheme , toppers answer scripts , revised exam pattern , revised syllabus , Blue Print etc. here **.Join Your Subject WhatsApp Group.**





Kindergarten

 **Click to Join**

Class 1  **Click to Join** **Class 2**  **Click to Join** **Class 3**  **Click to Join** **Class 4**  **Click to Join**







Class 5  **Click to Join** **Class 6**  **Click to Join** **Class 7**  **Click to Join** **Class 8**  **Click to Join**

Class 9  **Click to Join** **Class 10**  **Click to Join** **Class 11 (Science)**  **Click to Join** **Class 11 (Commerce)**  **Click to Join**

Class 11 (Humanities)  **Click to Join** **Class 12 (Science)**  **Click to Join** **Class 12 (Commerce)**  **Click to Join** **Class 12 (Humanities)**  **Click to Join**

Subject Wise Groups Secondary and Senior Secondary

Secondary Groups (IX & X)

SST  Click to Join	Mathematics  Click to Join	Science  Click to Join	English  Click to Join
Hindi  Click to Join	Information Technonology (402)  Click to Join		

Senior Secondary Groups (XI & XII)

Physics  Click to Join	Chemistry  Click to Join	English  Click to Join	Mathematics  Click to Join
Biology  Click to Join	Accountancy  Click to Join	Economics  Click to Join	BST  Click to Join
History  Click to Join	Geography  Click to Join	Sociology  Click to Join	Hindi Elective  Click to Join
Hindi Core  Click to Join	Home Science  Click to Join	Sanskrit  Click to Join	Psychology  Click to Join
Political Science  Click to Join	Painting  Click to Join	Vocal Music  Click to Join	Comp. Science  Click to Join
IP  Click to Join	Physical Education  Click to Join	App. Mathematics  Click to Join	IIT /NEET  Click to Join

Leagal Studies

 [Click to Join](#)

SOE CBSE Principals (Group for Principals Only)

 [Click to Join](#)

Teachers Jobs

 [Click to Join](#)

Rules & Regulations of the Group

1. No introduction
2. No Good Morning/Any wish type message
- 3.No personal Chats & Messages
4. No Spam
5. You can also ask your difficulties here.

Just get learning resources & post learning resources.

Helpline number only WhatsApp: +91-95208-77777

